

# WHY BUY SPECIAL TOOLS TO ACHIEVE DIFFERENT DIE HEIGHTS?

## USE THE WILSON QUICK CHANGE 1V DIE HOLDERS



There are times when you need different die heights to achieve the bends you require in your product. Each time a different height is required, special tools are purchased. When the job is completed, the tool is discarded. Over time, unused tools from completed jobs build up in your factory.

To prevent this problem, Wilson Tool offer European die holders in two different heights. With both holders available, you will be able to deal with the majority of die heights without purchasing special tools. Wilson Tool offer two styles of die rail; clamped and unclamped. It will depend on what type of dies you are using as to which you go for.

### Unclamped rails:

The benefit of unclamped rails is that the tool changeover time is quicker as the dies sit into a tight-tolerance die rail which holds the die in position. However, there is a problem with unclamped dies in that they can move sideways along the machine as parts are produced. Sectionalised tools are much more susceptible to this problem.

### Clamped die rails:

Clamped die rails prevent the problem of dies moving sideways during production. This is particularly important if you use a lot of sectionalised tooling. Clamped die rails can also be used unclamped, so this is a much more flexible option as the operator can choose which is best for individual set-ups.

The table below shows the different heights that can be achieved with the Wilson die holders.

Standard die height	Total height with 28 mm die holder	Total height with 51.5 mm die holder
30 mm	58 mm	81.5 mm
60 mm	88 mm	111.5 mm
83.5 mm	111.5 mm	135 mm

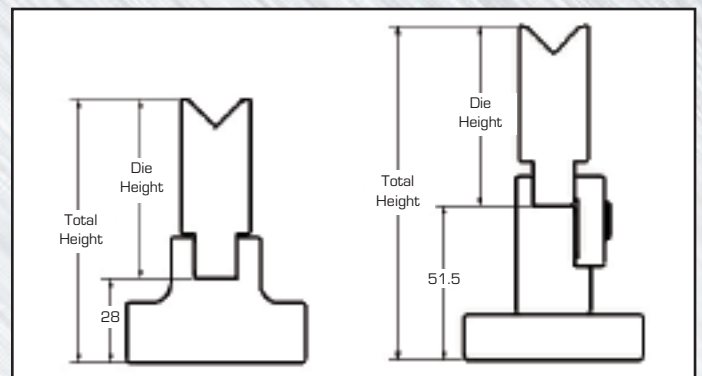

For advice and further information on any products contact Wilson Tool direct on: 0800 012 1475 (freephone) 1-800 70 90 09 (freephone Eire) or alternatively email [pbsales@wilsontool.eu.com](mailto:pbsales@wilsontool.eu.com)

Wilson Tool International (Europe) Ltd. Stirling Road, South Marston Industrial Estate, Swindon, Wiltshire SN3 4TQ

Free phone: 0800 012 1475 Tel: +44 (0) 1793 831818 Tel free: 1-800 70 90 09 Ireland

Free fax: 0800 012 1476 Fax: +44 (0) 1793 831945 Fax free: 1-800 53 55 38 Ireland

[www.wilsontool.com](http://www.wilsontool.com) [pbsales@wilsontool.eu.com](mailto:pbsales@wilsontool.eu.com)